



Hangcha Europe GmbH

Mariechen-Graulich-Straße 12a,
65439 Flörsheim am Main,
Germany

Administration
Tel: 0049-61453769188
E-mail: admin@hangchaeurope.com

Sales Management
Thomas Dittrich
Mob: 0049-16096548808
E-mail: thomas.dittrich@hangchaeurope.com

Technical Support
Thomas Pannke
Mob: 0049-01759284213
E-mail: thomas.pannke@hangchaeurope.com

www.hangchaeurope.com



Folgen Sie uns auf
Instagram



Folgen Sie uns auf
Facebook



Folgen Sie uns auf
YouTube



"Hangcha Forklift"
App herunterladen



ISO14001
ISO14001:2015



ISO9001
ISO9001:2015



HANGCHA trucks conform
to the European Safety
Requirements.

HANGCHA Group Co., LTD behält sich das Recht vor, Änderungen bezgl. Farbe, Spezifikationen, Ausstattung und sonstige Details, dierer Bröschüre ohne Vorankündigung vorzunehmen. Fahrzeugfarben können von den Farben in dieser Brochure abweichen.



XH SERIES

HIGH-VOLTAGE LITHIUM BATTERY FORKLIFT

With capacity of 28,000 to 35,000kg

BECOME THE FORKLIFT MEETING YOUR DIFFERENT NEEDS.

VOLTAGE

618 V

VEHICLE WATER RESISTANCE

IPX4

CHARGING TIME (20-100%)

1.0 Hour

TRAVEL SPEED

26km/h

SPEED MODELS

3 S/P/E mode
(Super/Power/Eco)

PROTECTION RATE

IP67



XH SERIES HIGH-VOLTAGE LITHIUM BATTERY FORKLIFT

Your reliable, powerful and connected working machine.

Independently developed by Hangcha on the basis of decades of deep understanding of electric forklifts and internal combustion forklifts, XH series high-voltage counterweight lithium battery forklifts are a new series of high-voltage counterweight lithium battery forklifts that first use a new energy vehicle voltage platform and represent a breakthrough over the traditional design concept. Representing a redefinition of electric forklifts in terms of efficiency, power, reliability, etc.,

XH series forklift models have performance and operating condition completely superseding that of the internal combustion forklifts.



FASTER EFFICIENCY

Through disruptive battery and fast charging technology, the charging time is greatly shortened.

Fast charging makes it possible for the whole vehicle to work continuously, shortening the waiting time and greatly improving efficiency.

LI-ION
TECHNOLOGY

6 YEARS
WARRANTY

HANGCHA provides Li-ion battery (LiFePO₄) with 6 years or 12000 hours warranty.

HIGH-VOLTAGE

282kWh

Battery capacity

THE *Plus*
FOR YOUR
BUSINESS

A PERFECT COMBINATION

With the inherited exterior design of X series internal combustion forklifts and a smooth and sturdy profile, the whole vehicle is stylish, sturdy and powerful, showing modern industrial aesthetics.



ADVANCEMENT

A high-torque permanent magnet synchronous motor provides strong power for the vehicle with performance indicators benchmarked against that of internal combustion forklifts.

Travel speed (km/h)

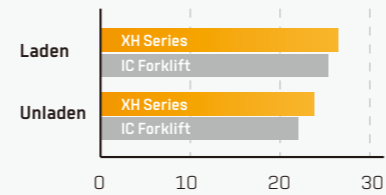

Max. gradeability(%)

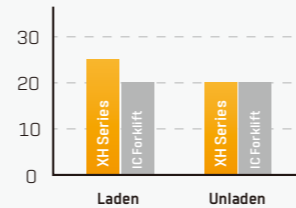

ULTRA LONG BATTERY LIFE

- A large-capacity lithium battery for the standard configuration can meet the long battery life need.
- Both the drive and operating systems are efficient and energy-saving vehicle-grade permanent magnet synchronization systems.
- High-voltage platform, less vehicle current and minimal system heat loss.
- A double-motor walking system increases the range of high efficiency and saves energy significantly.
- Braking energy recovery effectively prolongs operating time.



- A 618V high-voltage platform with low system loss, a standard chilled water tank for heavy-duty truck to achieve good heat dissipation.
- With motor, electric control and battery adopting liquid-cooling heat dissipation, the forklift can absolutely carry out long-time and high-intensity operations as internal combustion forklifts.



The vehicle has independently developed VCU program along with PDU+MCU+BMS+DC/DC to form a reliable and efficient drive system with flexible function configuration.



RELIABILITY AND SAFETY



The cover of the vehicle is designed to be sealed to the water resistance level of IPX4. All the motor and electronic controls reach the dust and water resistance level of IP67, a high protection level adequate to withstand harsh operating environments.



- Both the battery and junction box have MSD (Manual Service Disconnect) maintenance switches to enable one-click power-down and safer maintenance.
- The high-voltage lithium battery is equipped with an automatic fire extinguisher for the standard configuration. The vehicle is equipped with a pipe network automatic fire extinguisher for the standard configuration.



- The electrical system has high-voltage interlocking, insulation monitoring and potential balancing functions to offer vehicle-grade safety.
- Key structural parts have been verified highly reliable by the market for many years while being used by internal combustion forklifts.



A turning deceleration function effectively reduces risk of tipping over.



INTELLIGENCE

- A vehicle central controller is provided, which has bus architecture, several built-in diagnosis and management functions and a central fault alarm function.
- An optional intelligent management system is provided to enable intelligent remote monitoring and easier equipment management and logistics management.



MAINTAINABILITY

- The overturnable cab and electric tipping cylinder make tipping easier and more labor-saving.
- The wide-opened hood and removable cover better facilitate repair and maintenance of electrical components.



Technical Data

Distinguishing mark	HANGCHA GROUP CO.,LTD.							
	1.1	Manufacturer		CPD280-XHJG	CPD300-XHJG	CPD320-XHJG	CPD350-XHJG	
	1.2	Manufacturer's type designation		CPD280-XHJG	CPD300-XHJG	CPD320-XHJG	CPD350-XHJG	
	1.3	Drive: electric (battery or mains), diesel, petrol, fuel gas		Electric	Electric	Electric	Electric	
	1.4	Operator type: hand, pedestrian, standing, seated, order-picker		Seated	Seated	Seated	Seated	
	1.5	Rated capacity/rated load	Q (kg)	28000	30000	32000	35000	
	1.6	Load centre distance	c (mm)	1200	1200	1200	1200	
	1.8	Load distance, centre of drive axle to fork	x (mm)	1160	1160	1160	1180	
	1.9	Wheelbase	y (mm)	4750	4750	4750	4750	
Weight	2.1	Service Weight	kg	42400	44100	45200	48000	
	2.2	Axle loading, laden front/rear	kg	58500/11900	61800/12300	64400/12800	69000/14000	
	2.3	Axle loading, unladen front/rear	kg	20800/21600	21700/22400	22300/22900	23700/24300	
Tyres, chassis	3.1	Tyres: solid rubber, superelastic, pneumatic, polyurethane		Pneumatic	Pneumatic	Pneumatic	Pneumatic	
	3.2	Tyre size, front		16.00-25-32PR	16.00-25-32PR	16.00-25-32PR	16.00-25-36PR	
	3.3	Tyre size, rear		16.00-25-32PR	16.00-25-32PR	16.00-25-32PR	16.00-25-36PR	
	3.5	Wheels, number front / rear (x - driven wheels)		4/2	4/2	4/2	4/2	
	3.6	Tread, front	b10 (mm)	2462	2462	2462	2462	
	3.7	Tread, rear	b11 (mm)	2440	2440	2440	2440	
Dimensions	4.1	Tilt of mast/fork carriage forward/backward	$\alpha/\beta(^{\circ})$	6/10	6/10	6/10	6/10	
	4.2	Height, mast lowered	h1 (mm)	4100	4100	4100	4100	
	4.3	Free lift	h2 (mm)	110	110	110	110	
	4.4	Lift	h3 (mm)	4000	4000	4000	4000	
	4.5	Height, mast extended	h4 (mm)	6045	6045	6045	6045	
	4.7	Height of overhead guard (cabin)	h6 (mm)	3710	3710	3710	3710	
	4.8	Seat height/stand height	h7 (mm)	2420	2420	2420	2420	
	4.12	Coupling height	h10 (mm)	740	740	740	740	
	4.19	Overall length	l1 (mm)	9350	9350	9350	9370	
	4.20	Length to face of forks	l2 (mm)	6910	6910	6910	6930	
	4.21	Overall width	b2 (mm)	3420	3420	3420	3420	
	4.22	Fork dimensions	s/e/l (mm)	110/300/2440	110/300/2440	110/300/2440	125/300/2440	
	4.24	Fork-carriage width	b3 (mm)	3300	3300	3300	3300	
	4.25	Distance between fork-arms	b5 (mm)	1000-3000	1000-3000	1000-3000	1000-3000	
	4.31	Ground clearance, laden, below mast	m1 (mm)	300	300	300	300	
	4.32	Ground clearance, centre of wheelbase	m2 (mm)	450	450	450	450	
4.34.1	Aisle width for load length 2400mm	Ast (mm)	10360	10360	10360	10380		
4.35	Turning radius	Wa (mm)	6600	6600	6600	6600		
4.36	Internal turning radius	b13 (mm)	880	880	880	880		
Performance data	5.1	Travel speed, laden/unladen	km/h	24/26	24/26	24/26	24/26	
	5.2	Lift speed, laden/unladen	m/s	0.30/0.34	0.28/0.32	0.28/0.32	0.26/0.30	
	5.3	Lowering speed, laden/unladen	m/s	0.47/0.33	0.47/0.33	0.47/0.33	0.47/0.33	
	5.6	Max. Drawbar pull, laden/unladen	N	150000	150000	150000	150000	
	5.8	Max. gradeability, laden/unladen	%	20/25	20/25	20/25	20/25	
	5.9	Acceleration time, laden/unladen (0-10m)	s	5.0/4.3	5.0/4.3	5.2/4.5	5.2/4.5	
	5.10	Service brake		Wet disc brake system(WDB)				
		Parking brake		Spring Applied, Hydraulic release multidisc brake(SAHR)				
	Electric drivetrain	6.1	Drive motor rating S9 60 min Rated/Peak	kW	196/260	196/260	196/260	196/260
		6.2	Lift motor rating at S9 15% Rated/Peak	kW	2x85/125	2x85/125	2x85/125	2x85/125
6.4		Battery Capacity	kWh / Ah	282/456	282/456	282/456	282/456	
		Nominal Voltage	V	618	618	618	618	
6.5		Battery weight	kg	2600	2600	2600	2600	
Addition data	10.1	Operating pressure for attachments	MPa	16	16	16	16	
	10.2	Oil volume for attachments	l/min	120	120	120	120	
	10.3	Hydraulic Tank - capacity (drain & refill)	liter	610	610	610	610	
	10.7	Sound pressure level at the driver's seat	dB (A)	70	70	70	70	

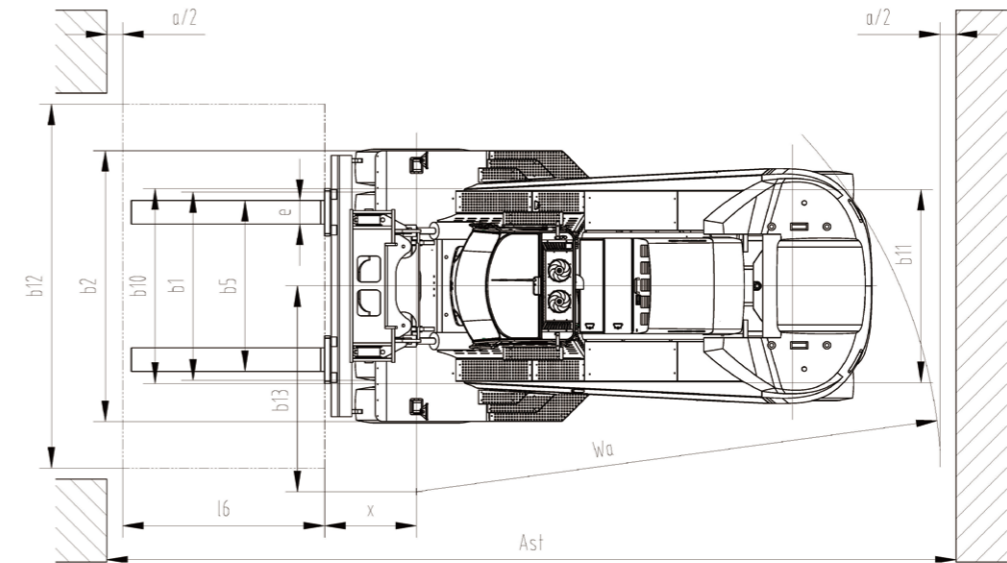
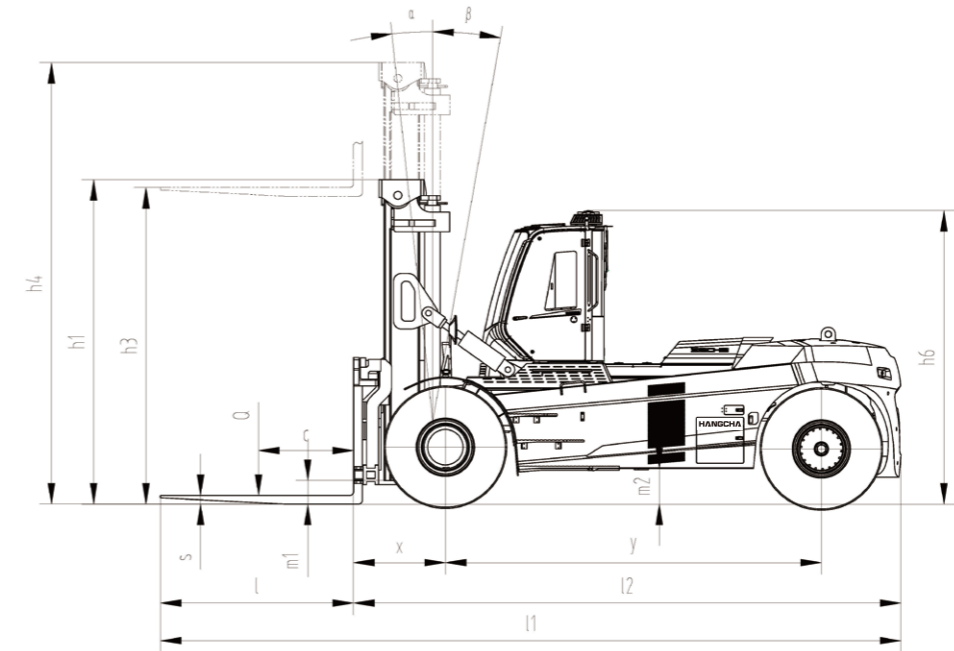

$$Ast = l6 + Wa + x + a/2 \quad \text{load length } a: \text{Clearance } (200\text{mm})$$

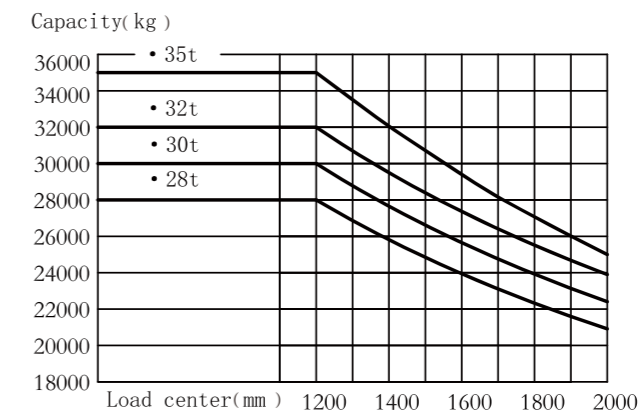

28-32t Mast Specification:(Pneumatic)

Type	Model	Max. fork height	Overall height		Tilt range	Capacity		
			Lowered	Extended	FWD/RWD	Load capacity at 1200mm		
		mm	mm	mm	(°)	28t	30t	32t
Wide view mast	GXR280/320M360	3600	3900	5690	6/10	28000	30000	32000
	GXR280/320M400	4000	4100	6090	6/10	28000	30000	32000
	GXR280/320M430	4300	4250	6390	6/10	28000	30000	32000
	GXR280/320M450	4500	4350	6590	6/10	28000	30000	32000
	GXR280/320M480	4800	4500	6890	6/10	28000	30000	32000
	GXR280/320M500	5000	4650	7140	6/10	28000	30000	32000
	GXR280/320M550	5500	4900	7640	3/6	26500	28500	30500
	GXR280/320M600	6000	5200	8190	3/6	25000	27000	29000
	GXR280/320M650	6500	5450	8690	3/6	23000	25000	27000
	GXR280/320M700	7000	5750	9240	3/6	21000	23000	25000

35t Mast Specification:(Pneumatic)

Type	Model	Max. fork height	Overall height		Tilt range	Capacity
			Lowered	Extended	FWD/RWD	Load capacity at 1200mm
		mm	mm	mm	(°)	35t
Wide view mast	GXR350M360	3600	4150	5940	6/10	35000
	GXR350M400	4000	4350	6340	6/10	35000
	GXR350M430	4300	4500	6640	6/10	35000
	GXR350M450	4500	4600	6840	6/10	35000
	GXR350M480	4800	4750	7140	6/10	35000
	GXR350M500	5000	4900	7390	6/10	35000
	GXR350M550	5500	5150	7890	3/6	33500
	GXR350M600	6000	5450	8440	3/6	32000
	GXR350M650	6500	5700	8940	3/6	30000
	GXR350M700	7000	6000	9490	3/6	28000



Features

Transmission	Standard	Options
Pneumatic tyre	●	
Solid tyre		○
Steering system		
Fully hydraulic power steering	●	
Centralized lubrication system (machine)		○
Truck		
Tow pin	●	
Electrostatic discharge chain	●	
Rear-view mirror on right & left mudguards	●	
Operating system		
Integrated joystick	●	
Adjustable steering column	●	
Adjustable armrest	●	
Hydraulic system		
Variable hydraulic pump system	●	
Four-way hydraulic valve		○
Operation proportion control	●	
Cab		
Cabin	●	
Climate control system (air-conditioning and heater)	●	
Manual tilting cabin	●	
Electric tilting cabin	●	
Radio	●	
Sunshade	●	
USB charging interface	●	
Clothes hanger hook	●	
Reading light	●	
1 x 24V power supply		○
1 x 12V power supply		○
License plate frame		○
Fan	●	
Lifting components		
Duplex mast	●	
Standard lifting height	●	
Optional lifting height		○
Standard fork	●	
Other fork specifications		○
Fork hook on type		○
Hydraulic Fork Positioning	●	
Independently-adjustable fork		○
Built in Sideshift	●	
Other		
Standard color	●	
User defined colour		○
Vehicle toolkit	●	

Electrical System	Standard	Options
Operator Presense System (OPS) with buzzer	●	
LCD display screen	●	
Main power switch	●	
Emergency power off switch	●	
Maintenance-free 24V lead acid battery	●	
Reverse buzzer	●	
High decible horn	●	
LED lights (entire vehicle)	●	
2 x Working light on front mudguard	●	
2 x Front working light on top of cabin	●	
2 x Rear working light on top of cabin	●	
2 x Working light on both sides of mast	●	
Reverse sensor	●	
Rearview camera system	●	
Rearview camera system with memory		○
Front & rearview camera system		○
Front & rearview camera system with memory		○
4 directions camera system with single display		○
4 directions camera recording system with single display		○
Rear blue safety light		○
Front and rear blue safety light		○
Three sided blue danger zone light		○
Overspeed alarm		○
Speed limitation		○
Voice reverse alarm		○
Automatic fire suppression system	●	
Automatic fire suppression system for lithium battery pack	●	
Two-way radio		○
Weight indicator in display		○
Flashing warning light (non rotating) with control switch	●	
Tyre pressure monitoring		○
On-board diagnostics system	●	
Water cooling system for lithium battery	●	
Manual Service Disconnect (MSD) switch	●	
High voltage interlock	●	
Insulation protection	●	
Power-on self-test	●	
Energy recovery (braking regeneration)	●	
Vehicle Control Unit (VCU)	●	
Dual charging ports	●	
Turning deceleration		○
Hour meter	●	
Battery charge indicator	●	
Low hydraulic pressure alarm indicator	●	
Hydraulic oil filter warning indicator	●	
Drive mode indicator	●	
Parking brake indicator	●	
Service indicator	●	
In cabin CCTV		○