



Hangcha Europe GmbH

Mariechen-Graulich-Straße 12a,
65439 Flörsheim am Main,
Germany

Administration
Tel: 0049-61453769188
E-mail: admin@hangchaeurope.com

Sales Management
Thomas Dittrich
Mob: 0049-16096548808
E-mail: thomas.dittrich@hangchaeurope.com

Technical Support
Thomas Pannke
Mob: 0049-01759284213
E-mail: thomas.pannke@hangchaeurope.com

www.hangchaeurope.com



Folgen Sie uns auf
Instagram



Folgen Sie uns auf
Facebook



Folgen Sie uns auf
YouTube



"Hangcha Forklift"
App herunterladen



ISO14001
ISO14001:2015



ISO9001
ISO9001:2015



HANGCHA trucks conform
to the European Safety
Requirements.

2024 VERSION 1 / COPYRIGHT 2024/09

HANGCHA Group Co., LTD behält sich das Recht vor, Änderungen bezgl. Farbe, Spezifikationen, Ausstattung und sonstige Details, dierer Bröschüre ohne Vorankündigung vorzunehmen. Fahrzeugfarben können von den Farben in dieser Brochure abweichen.

X Series Empty Container Handler

with capacities of 9,000kg

STAGE V
CERTIFIED

REACH
THE SKY



The World of Hangcha
SINCE 1956



X Series Empty Container Handler

A new generation high-quality professional product, which is newly developed on the basis of Hangcha's X series platforms and years of industry experience and extensively adopts advanced technologies, is mainly used in the loading, handling and stacking operations of empty 20ft and 40ft ISO containers.

Reliable

- / The gearbox(DANA), drive axle(KESSLER), engine and key hydraulic parts are all have stable and reliable quality.
- / The accumulated years of industry experience, digital product design, finite element analysis, kinematic and dynamic simulation calculation, field verification, and fatigue, overload, strain tests ensure the reliable structure of the truck.
- / The mast is made of high-strength steel and has an ultra-wide structure designed. The installation point of the inclined oil cylinder is arranged at a high position to improve the rigidity and stability of the truck.
- / The truck's heat dissipation management system automatically adjusts the heat dissipation intensity, so that each system can quickly enter the efficient operating state. The large heat dissipation capacity design ensures the requirements for the heat dissipation in high temperature environments to be met.
- / With waterproof and dust-proof design, the electrical system has higher reliability.
- / The novel spreader has a higher reliability, a longer service life, a lower failure rate and a lower maintenance cost.





Comfortable

- / The instruments with high-definition color screens display the truck status in real time and the fault alarm enable easier maintenance.
- / The new generation electronically-controlled gearbox enables flexible, smooth and comfortable gear shifting.



Efficient

- / The throttle following control provided for controlling the engine speed, the single-hand joystick and the electric proportional control enable flexible, accurate and efficient control.
- / Higher lifting speed and faster dynamic response enable the operation efficiency to be effectively improved.
- / Easy maintenance design a wide-opened hood, a large-space electric control box, a larger cab space, multiple hydraulic inspection points, easy access to the oil and water during inspection, and built-in diagnostic and query functions of the smart instruments.



Safe

- / The spreader twist-lock equipped with mechanical and electrical protection devices, lifting interruption control, OPS system, travel speed limiting and other functions ensure safe operations.
- / The LED lighting system ensures the brightness of the lighting within the operating range.
- / A visual reversing radar is provided for the standard configuration and other options such as an automatic fire extinguishing system, tire pressure monitoring, overload protection, etc. can be provided.

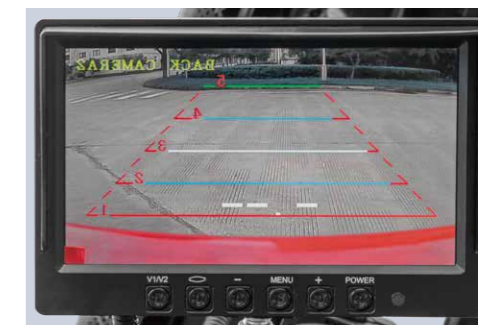

Fully-suspended all-round vision cab

- / The movable fully-suspend cab, easy for maintenance.
- / With the vehicle frame damper connected and the tight sound and heat insulation design, most vibration and noise are shielded.
- / The largely-curved front and rear windows, all-glass left and right doors and large glass ceiling enable a broad view.
- / An inclinable telescopic steering column and fully-suspended adjustable seat with a high backrest and safety belt, with seat sensing and driving position sensing functions.
- / A high-power cooling and heating air conditioner, two ventilation modes - internal and external circulation, sunshades, speed-adjustable wipers and defrosting function make driving more comfortable.



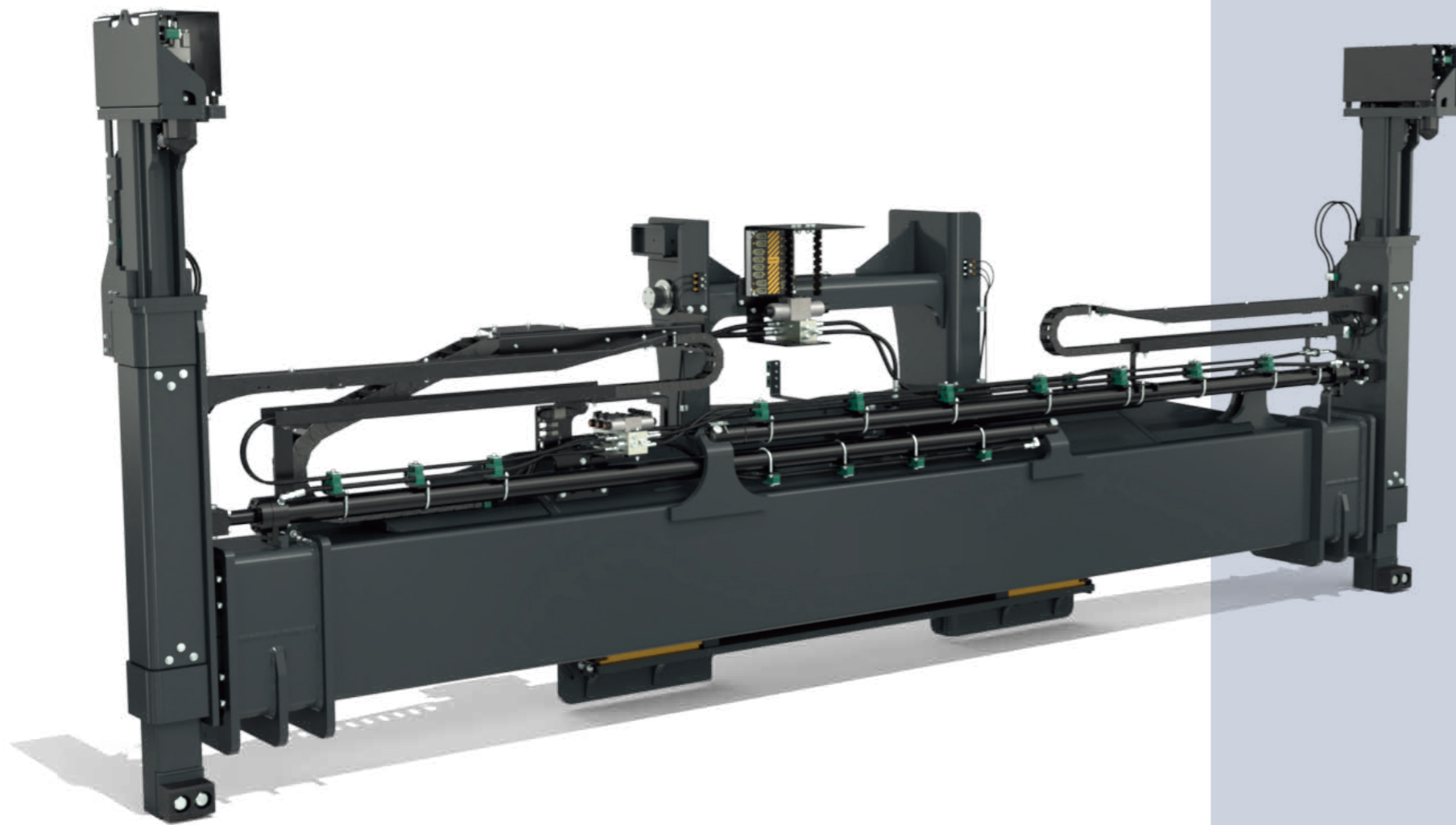

TECHNICAL SPECIFICATIONS

Type of lifting system	Two vertical twistlocks
Type of stacking	Normal and block stacking
Spreader weight (TW)	3 600 kgs
Carriage weight (MPS)	1 050 kgs
Lifting capacity (SWL)	9 tonnes
Telescopic positions	20 and 40ft
Telescoping speed, 20-40ft	< 12 sec.*
Telescoping speed, 40-20ft	< 14 sec.*
Sideshift	± 600 optional ± 400 mm
Mechanical pile slope (MPS), vertical floating end-posts	At 20ft position: approx. 200 mm At 40ft position: approx. 200 mm
Hydraulics, operating pressure up to	140 bar
Hydraulics, flow	40-60 L/min
Electric - control voltage	24 VDC
Communication	CAN 2.0B
Colour	Black grey RAL 7021

* Calculated speed at 60 L/min

Single handling container spreader Vertical Twistlocks.

Suitable for:

- / 20' or 40' ISO containers of 8' (2.44 m) width.
- / Approx. 2.45-2.50 m wide "pallet-wide" 20' or 40' containers, with ISO-like 'chamfered' corner castings.
- / With speed limitation for laden/unladen.

Not suitable for:

- / Approx. 2.45 - 2.60 m wide "CPC" containers (Cellular Pallet-wide Containers) with non-ISO corner castings.
- / Approx. 2.45 - 2.50 m wide "pallet-wide" 20' or 40' containers, with ISO-like 'chamfered' corner castings.



Improved design with built-in cabling and larger bending radius for hydraulic hose between pocket and end-post.



INNOVATION head.

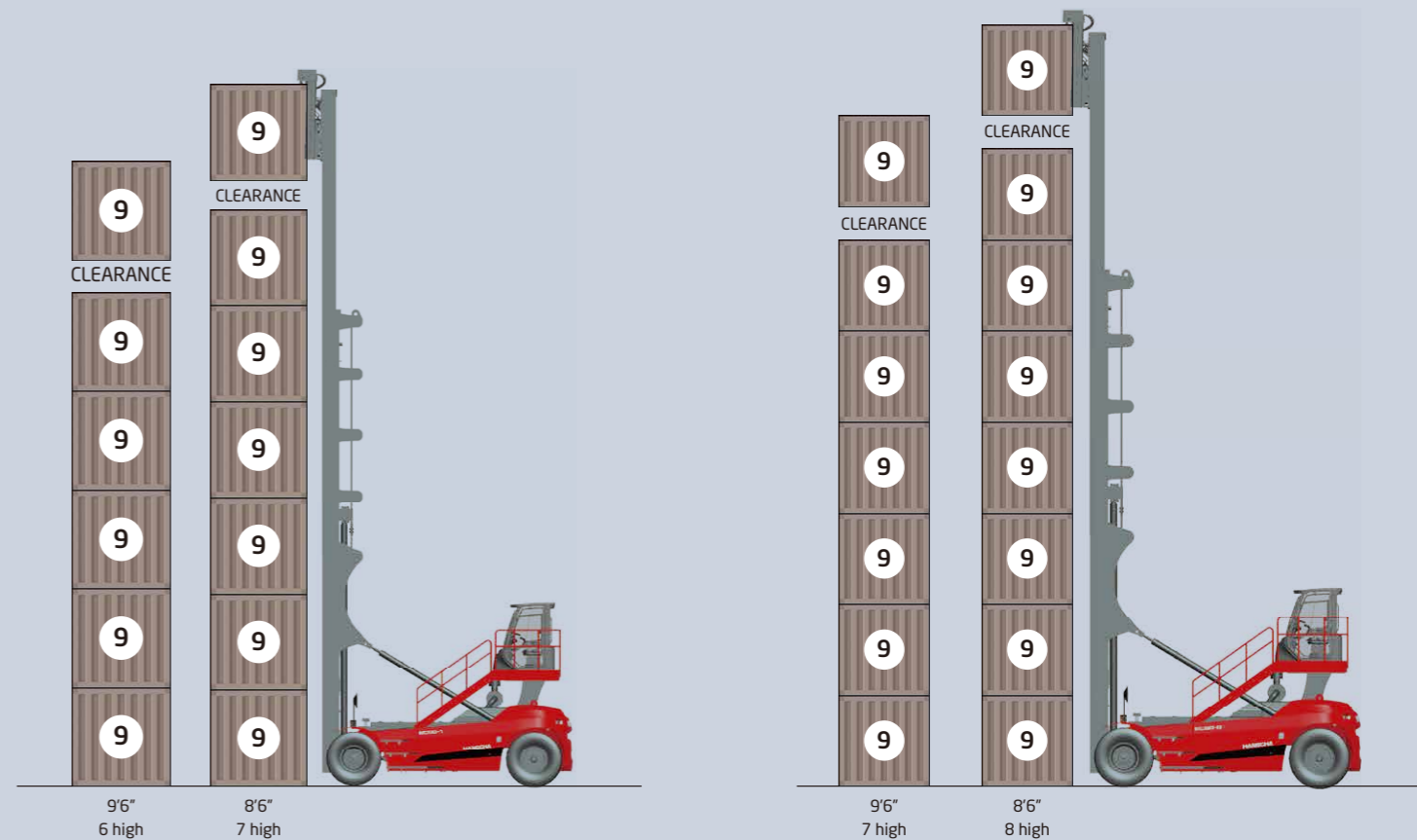
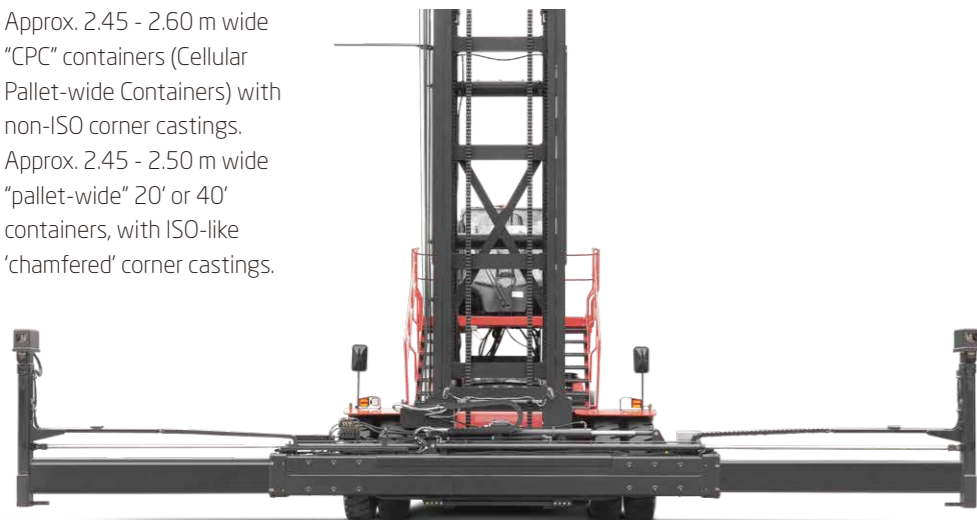

H90EC-7-XRW83/H90EC-7-XRH10

H90EC-8-XRW83/H90EC-8-XRH10



Standard Specification

- / Duplex mast
- / Standard lifting height
- / Spreader & twistlock double protection
- / Emergency descent
- / Twistlock counter
- / 2 x Spreader twistlock light
- / Standard color
- / Vehicle toolkit
- / Pneumatic tyre
- / Fully hydraulic power steering
- / Extended exhaust pipe
- / Lockable fuel cap
- / Pre-cleaner air filter
- / Tow pin
- / Rear-view mirror on right & left mudguards
- / Integrated joystick
- / Adjustable steering column
- / Adjustable armrest
- / Operation proportion control
- / Operator Presense System (OPS) with buzzer
- / LCD display screen
- / Main power switch
- / Emergency power off switch
- / Maintenance-free 24V lead acid battery
- / Reverse buzzer
- / High decible horn
- / LED lights (entire vehicle)
- / 2 x Working light on front mudguard
- / 2 x Front working light on top of cabin
- / 2 x Rear working light on top of cabin
- / 2 x Working light on both sides of mast
- / Reverse sensor
- / Rearview camera system
- / Flashing warning light (non rotating) with control switch
- / On-board diagnostics system
- / Override switch
- / Engine fault alarm
- / Engine oil pressure alarm indicator
- / Air filter warning indicator
- / Water temperature indicator
- / Hour meter
- / Battery charge indicator
- / Low hydraulic pressure alarm indicator
- / Hydraulic oil filter warning indicator
- / Oil gauge
- / Fuel-water separator warning indicator
- / Oil temperature gauge
- / Pre-heat indicator
- / Drive mode indicator
- / Parking brake indicator
- / Service indicator
- / Cabin
- / Climate control system (air-conditioning and heater)
- / Radio
- / Sunshade
- / USB charging interface
- / Clothes hanger hook
- / Reading light
- / Fan

Options

- / Optional lifting height
- / User defined colour
- / Fire extinguisher (2kg/4kg)
- / Solid tyre
- / Centralized lubrication system (machine)
- / Spark arrester
- / Electrostatic discharge chain
- / Rearview camera system with memory
- / Front & rearview camera system
- / Front & rearview camera system with memory
- / 4 directions camera system with single display
- / 4 directions camera recording system with single display
- / In cabin CCTV
- / Rear blue safety light
- / Front and rear blue safety light
- / Three sided blue danger zone light
- / Overspeed alarm
- / Speed limitation
- / Voice reverse alarm
- / Automatic fire suppression system
- / Two-way radio
- / Weight indicator in display
- / Tyre pressure monitoring
- / 1 x 24V power supply
- / 1 x 12V power supply
- / License plate frame
- / Mast automatic vertical realignment
- / Lifting height indicator on display
- / Dynamic speed Limit depending of lift height(customer defined)



X Series Empty Container Handler Specification

		HANGCHA GROUP CO.,LTD.						
Distinguishing mark	1.1	Manufacturer						
	1.2	Manufacturer's type designation	H90EC-7-XRW83	H90EC-8-XRW83	H90EC-7-XRH10	H90EC-8-XRH10		
	1.3	Drive: electric (battery or mains), diesel, petrol, fuel gas	Diesel	Diesel	Diesel	Diesel		
	1.4	Operator type: hand, pedestrian, standing, seated, order-picker	Seated	Seated	Seated	Seated		
	1.5	Rated capacity/rated load	Q (kg)	9000	9000	9000	9000	
	1.6	Stacking height, no. of containers (8'6" / 9'6")		7/6	8/7	7/6	8/7	
	1.7	Load centre distance	c (mm)	1220	1220	1220	1220	
	1.8	Load distance, centre of drive axle to fork	x (mm)	1340	1340	1340	1340	
	1.9	Wheelbase	y (mm)	4550	4550	4550	4550	
Weight	2.1	Service Weight	kg	39800	41000	39800	41000	
Tyres, chassis	3.1	Tyres: solid rubber, superelastic, pneumatic, polyurethane	Pneumatic	Pneumatic	Pneumatic	Pneumatic		
	3.2	Tyre size, front	14.00-24-28PR	14.00-24-28PR	14.00-24-28PR	14.00-24-28PR		
	3.3	Tyre size, rear	14.00-24-28PR	14.00-24-28PR	14.00-24-28PR	14.00-24-28PR		
	3.5	Wheels, number front / rear (x = driven wheels)	4/2	4/2	4/2	4/2		
	3.6	Tread, front	b10 (mm)	3280	3280	3280	3280	
	3.7	Tread, rear	b11 (mm)	2300	2300	2300	2300	
	Dimensions	4.1	Tilt of mast/fork carriage forward/backward	$\alpha/\beta(^{\circ})$	3/4	3/4	3/4	3/4
4.2		Height, mast lowered	h1 (mm)	10715	12015	10715	12015	
4.3		Lift height, min in twist locks	h2 (mm)	2200	2200	2200	2200	
4.4		Lift height, max in twist locks	h3 (mm)	18670	21270	18670	21270	
4.5		Height, mast extended	h4 (mm)	19100	21700	19100	21700	
4.7		Height of overhead cabin	h6 (mm)	4600	4600	4600	4600	
4.8		Seat height relating to SIP	h7 (mm)	3500	3500	3500	3500	
4.12		Coupling height	h10 (mm)	740	740	740	740	
4.19		Overall length	l1 (mm)	7020	7020	7020	7020	
4.20		Length to face of forks	l2 (mm)	6850	6850	6850	6850	
4.21		Overall width	b1/b2(mm)	4120/2700	4120/2700	4120/2700	4120/2700	
4.22		Spreader sideshift	mm	± 600	± 600	± 600	± 600	
4.24		Spreader width, retracted	b3 (mm)	6100	6100	6100	6100	
4.25		Spreader width, extended	b5 (mm)	12240	12240	12240	12240	
4.31		Ground clearance, laden, below mast, laden/unladen	m1 (mm)	280/290	280/290	280/290	280/290	
4.32		Ground clearance, centre of wheelbase	m2 (mm)	300	300	300	300	
4.34		Aisle width with(20' / 40')	As1 (mm)	10400/14500	10400/14500	10400/14500	10400/14500	
4.35		Turning radius	Wa (mm)	6000	6000	6000	6000	
4.36		Minimum pivoting point distance	b13 (mm)	2085	2085	2085	2085	
Performance data		5.1	Travel speed, laden/unladen	km/h	26/28	26/28	26/28	26/28
		5.2	Lift speed, laden/unladen	m/s	0.55/0.62	0.55/0.62	0.55/0.62	0.55/0.62
	5.3	Lowering speed, laden/unladen	m/s	0.5/0.55	0.5/0.55	0.5/0.55	0.5/0.55	
	5.5	Drawbar pull, laden	N	160000	160000	160000	160000	
	5.7	Gradeability, laden	%	22	22	22	22	
	5.10	Service brake		Wet disc brake	Wet disc brake	Wet disc brake	Wet disc brake	
		Parking brake		spring applied, hydraulic release multi-disc brake	spring applied, hydraulic release multi-disc brake	spring applied, hydraulic release multi-disc brake	spring applied, hydraulic release multi-disc brake	
	7.1	Engine manufacturer/type		Volvo TAD851VE	Volvo TAD851VE	Volvo TAD881VE	Volvo TAD881VE	
		Emission STD		StageIIIA/Tier3	StageIIA/Tier3	EU StageV	EU StageV	
	7.2	Engine power	kW	185	185	185	185	
7.3	Rated speed	r/min	2200	2200	2200	2200		
7.4	Number of cylinders/displacement	(-)/(cm³)	6/7700	6/7700	6/7700	6/7700		
Engine	7.9	Vehicle electrical system voltage	V	24	24	24	24	
	7.10	Battery voltage/nominal capacity	V/Ah	2×12/150	2×12/150	2×12/150	2×12/150	
		Rated torque	N·m/r/min	1160/1350	1160/1350	1175/1400	1175/1400	
		Transmissions Manufacturer		DANA	DANA	DANA	DANA	
		Stage FWD/RVS		3/3	3/3	3/3	3/3	
Addition data	10.1	Operating pressure for attachments	Mpa	17.5	17.5	17.5	17.5	
	10.2	Oil volume for attachments	l/min	120	120	120	120	
	10.3	Hydraulic Tank - capacity (drain & refill)	liter	460	460	460	460	
	10.4	Fuel tank capacity	liter	620	620	620	620	
	10.7	Sound pressure level at the driver's seat	dB (A)	72	72	72	72	

